



AmericanTechnology
CORPORATION

Shaping the future of sound®

LRAD®

SCRAM CART PRODUCT SHEET

SCRAM CART FEATURES:

- GFCI WHILE ON BATTERY POWER
- ANTI-SKID PLATFORM/BATTERY COVER
- AUDIBLE LOW-BATTERY INDICATOR
- INTEGRATED BATTERY CHARGER



The SCRAM Cart is a portable platform specifically designed for use with the directed acoustic hailing, warning, and notification system, LRAD 1000. The mobile configuration increases the effectiveness of the LRAD by enabling rapid deployment, transportation and stowage by a single operator.

The ruggedized, weatherproof system includes a self-contained battery pack that provides up to 6 hours of continuous operation at full power, thereby eliminating the need for power outlets and extension cords. An integrated marine battery charger is also standard with the system.

The SCRAM Cart is designed with a low center of gravity for high stability on rolling ship decks and inclined surfaces. The system consists of marine-grade aluminum construction and environmentally sealed and potted electronics for high reliability in harsh environments.

Whether used in sea or on land applications, this portable unit enhances the efficiency of the LRAD system through rapid, trouble-free operation and transportation.



Long Range Acoustic Device™

UNIT WEIGHT

Without LRAD Unit

Approximately 155 lbs

UNIT COLOR

Haze Gray ■

Catalog No. LRAD-CART-SCRAM

MECHANICAL

Unit Dimensions Without LRAD Unit

29" W x 40.5" D x 45" H

ENVIRONMENTAL

Ingress Protection Class
Operating Environment

(EN60529) IP56
0° to 45°

TECHNICAL PERFORMANCE

Tilt Stability

30° Side-to-Side
20° Forward
>30° Backward

Batteries

4x AGM (Absorbed Glass Mat)
4 x 18 Amp - hours

Power Input

90 - 240 VAC 50 - 60 Hz

Power Output

12 VDC
115 ~ VAC on Battery Power
Pass-through when plugged in

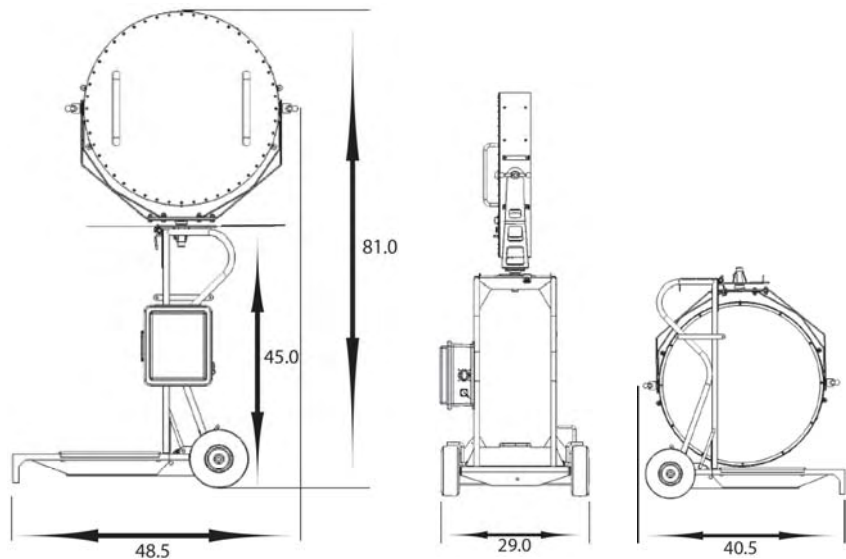

Shaping the future of sound®

15378 Avenue of Science, Suite 100 San Diego, CA 92128 USA

Tel: 858.676.1112 Fax: 858.676.1120 Email: Sales@atcsd.com

Web: www.atcsd.com

PART NO. 105364-19 LAST MODIFIED 05/21/08